

• General Description

The ZM350P10P combines advanced trench MOSFET technology with a low resistance package to provide extremely low $R_{DS(ON)}$.

• Features

- Advance high cell density Trench technology
- Low $R_{DS(ON)}$ to minimize conductive loss
- Low Gate Charge for fast switching
- Low Thermal resistance

• Application

- MB/VGA Vcore
- SMPS 2nd Synchronous Rectifier
- POL application
- BLDC Motor driver

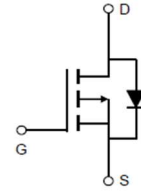
• Product Summary

$V_{DS} = -100V$

$R_{DS(ON)} = 35m\Omega$

$I_D = -35A$

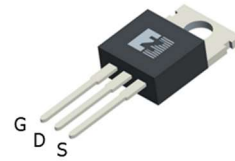

TO-220

• Ordering Information:

Part NO.	ZM350P10P
Marking	ZM350P10
Packing Information	REEL TAPE
Basic ordering unit (pcs)	1000

• Absolute Maximum Ratings ($T_c = 25^\circ C$)

Parameter	Symbol	Rating	Unit
Drain-Source Voltage	V_{DS}	-100	V
Gate-Source Voltage	V_{GS}	± 20	V
Continuous Drain Current	$I_{D@TC=25^\circ C}$	-35	A
	$I_{D@TC=75^\circ C}$	-27	A
	$I_{D@TC=100^\circ C}$	-22	A
Pulsed Drain Current ^①	I_{DM}	-105	A
Total Power Dissipation($TC=25^\circ C$)	$P_D@TC=25^\circ C$	55	W
Total Power Dissipation($TA=25^\circ C$)	$P_D@TA=25^\circ C$	2	W
Operating Junction Temperature	T_J	-55 to 150	$^\circ C$
Storage Temperature	T_{STG}	-55 to 150	$^\circ C$
Single Pulse Avalanche Energy@ $L=0.1mH$	E_{AS}	120	mJ

•Thermal resistance

Parameter	Symbol	Min.	Typ.	Max.	Unit
Thermal resistance, junction - case	R_{thJC}	-	-	2.1	$^{\circ}C/W$
Thermal resistance, junction - ambient	R_{thJA}	-	-	62	$^{\circ}C/W$
Soldering temperature, wavesoldering for 10s	T_{sold}	-	-	265	$^{\circ}C$

•Electronic Characteristics

Parameter	Symbol	Condition	Min.	Typ	Max.	Unit
Drain-Source Breakdown Voltage	BV_{DSS}	$V_{GS} = 0V, I_D = -250\mu A$	-100			V
Gate Threshold Voltage	$V_{GS(TH)}$	$V_{GS} = V_{DS}, I_D = -250\mu A$	-1.2		-2.5	V
Drain-Source Leakage Current	I_{DSS}	$V_{DS} = -100V, V_{GS} = 0V$			-1.0	μA
Gate- Source Leakage Current	I_{GSS}	$V_{GS} = \pm 20V, V_{DS} = 0V$			± 100	nA
Static Drain-source On Resistance	$R_{DS(ON)}$	$V_{GS} = -10V, I_D = -15A$		38	50	$m\Omega$
		$V_{GS} = -4.5V, I_D = -8A$		42	55	$m\Omega$
Forward Transconductance	g_{FS}	$V_{DS} = -10V, I_D = -10A$		20		s
Source-drain voltage	VSD	$I_s = -15A$			-1.28	V

•Electronic Characteristics

Parameter	Symbol	Condition	Min.	Typ	Max.	Unit
Input capacitance	C_{iss}	$V_{DS} = -25V$ $f = 1MHz$	-	4500	-	pF
Output capacitance	C_{oss}		-	398	-	
Reverse transfer capacitance	C_{rss}		-	157	-	

•Gate Charge characteristics($T_a = 25^{\circ}C$)

Parameter	Symbol	Condition	Min.	Typ	Max.	Unit
Total gate charge	Q_g	$V_{DD} = -15V$	-	124	-	nC
Gate - Source charge	Q_{gs}	$I_D = -15A$	-	20	-	
Gate - Drain charge	Q_{gd}	$V_{GS} = -10V$	-	29	-	

Note: ① Pulse Test : Pulse width $\leq 300\mu s$, Duty cycle $\leq 2\%$;

② Device mounted on FR-4 substrate PC board, 2oz copper, with thermal bias to bottom layer 1inch square copper plate;

Fig.1 Gate-Charge Characteristics

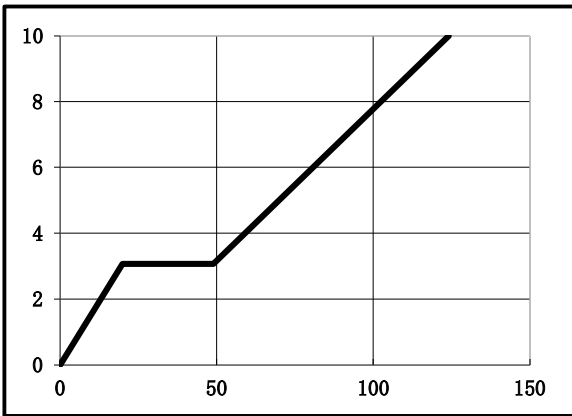

Fig.2 Capacitance Characteristics

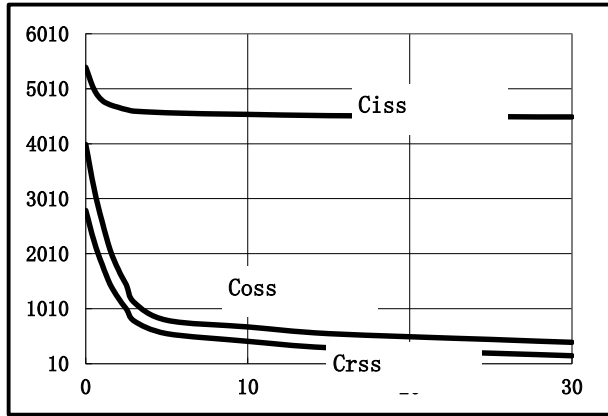

Fig.3 Power Dissipation

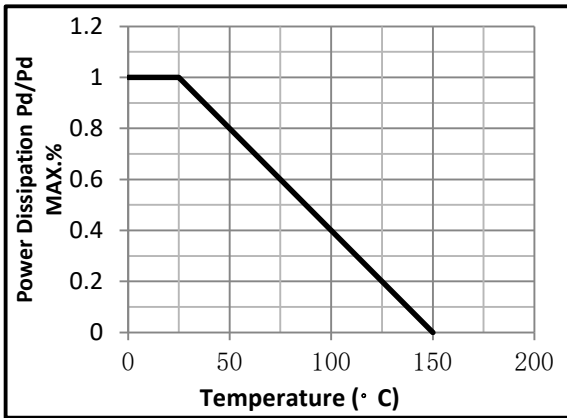

Fig.4 Typical output Characteristics

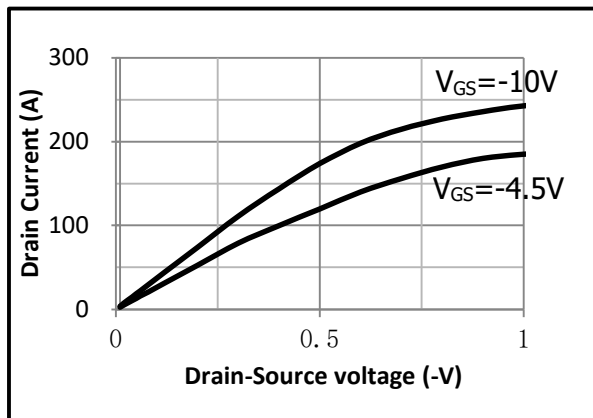

Fig.5 Threshold Voltage V.S Junction Temperature

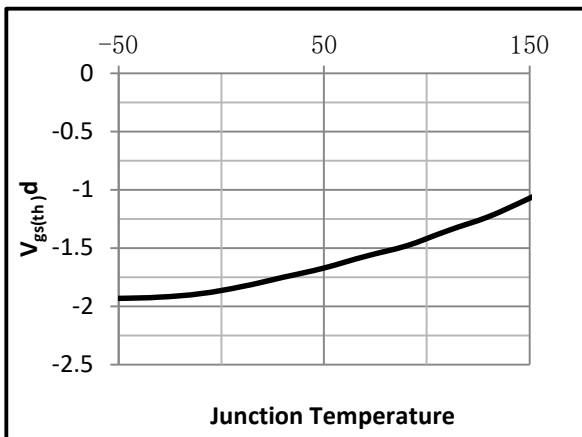

Fig.6 Resistance V.S Drain Current

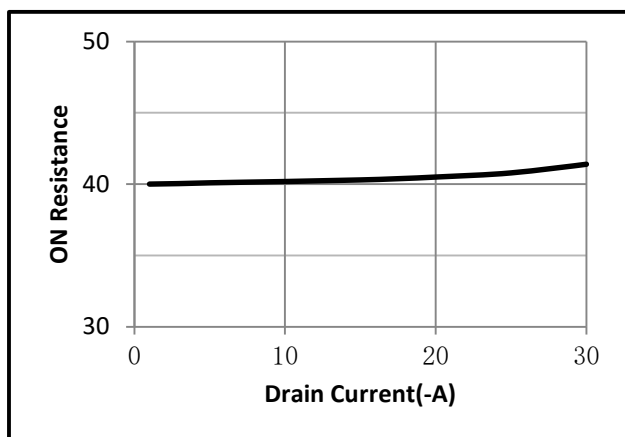

Fig.7 On-Resistance VS Gate Source Voltage

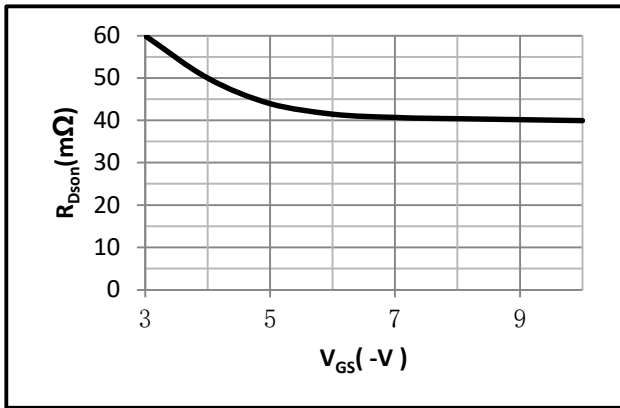

Fig.8 On-Resistance V.S Junction Temperature

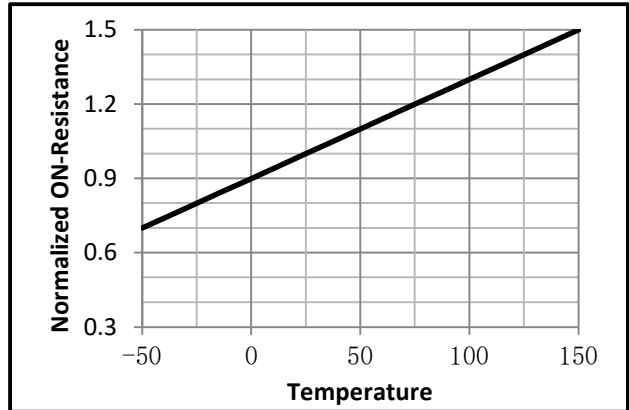

Fig.9 Gate Charge Measurement Circuit

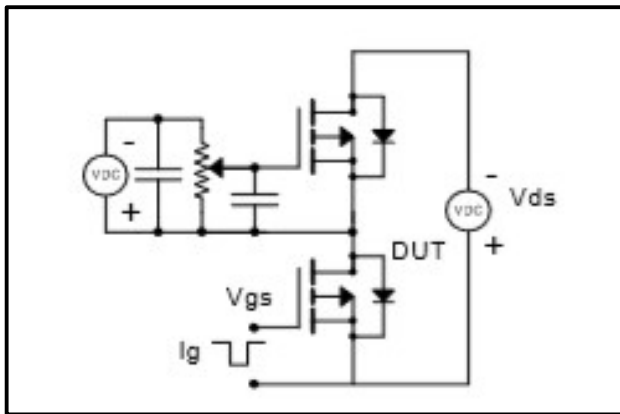

Fig.10 Gate Charge Waveform

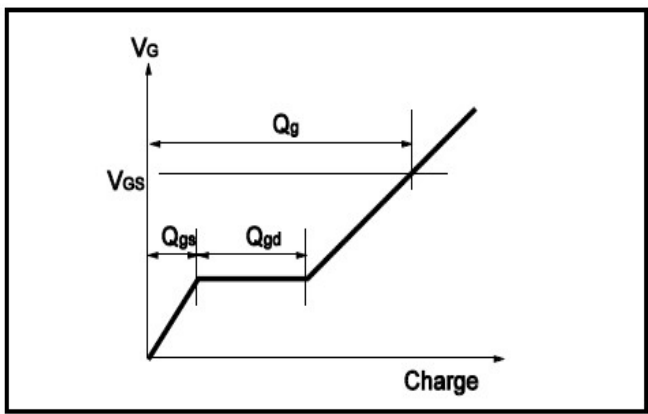

Fig.11 Switching Time Measurement Circuit

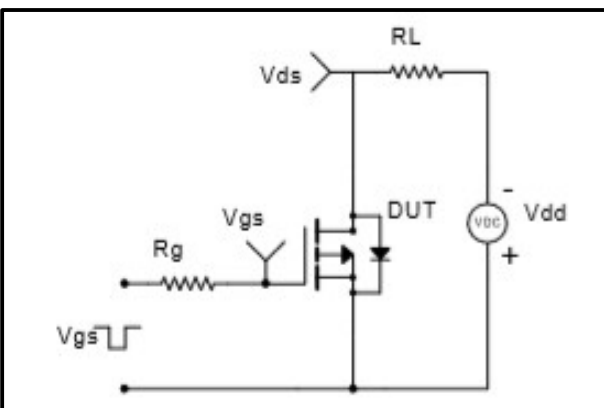
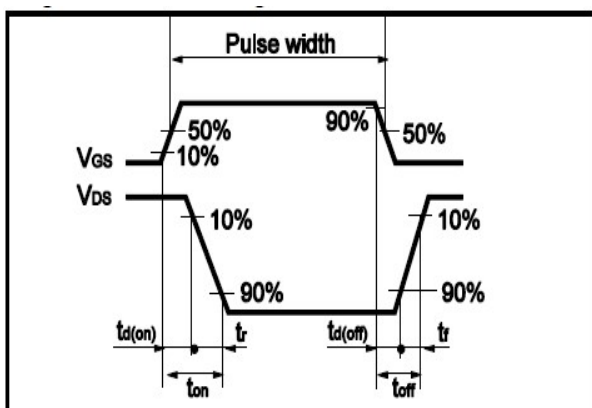

Fig.12 Switching Time Waveform





• Dimensions (TO-220)

Unit: mm

SYMBOL	min	nom	max	SYMBOL	min	nom	max
A	4.00		4.80	E	9.90		10.70
B	1.20		1.50	e		2.54	
B1	1.00		1.40	F	1.10		1.45
b1	0.65		1.00	L	12.50		14.50
c	0.35		0.75	L1	3.00	3.50	4.00
D	15.00		16.50	Q	2.50		3.00
D1	5.90		6.90	Q1	2.00		3.00
				ΦP	3.60		3.90

